

Operating Instructions

使用说明书



5 Inch LED Digital Magnetic Hotplate Stirrer
5寸数显加热磁力搅拌器

Contents

Safety Instructions	2
Inspection	4
Control	5
Trial run	7
Heating	7
Working with the external temperature sensor	8
Residual heat warning (Hot)	8
Stirring	9
Faults	9
Error codes	10
Maintenance	10
Standards and regulations	11
Specifications	12
Warranty	13

Safety Instructions



For your protection

- **Read the operating instructions in full before starting up and follow the safety instructions when in use.**
- Ensure that only trained staff work with the device.
- Socket must be earthed (protective ground contact).
- **Caution-Magnetism!** Effects of the magnetic field have to be taken in to account (e.g. data storage media, cardiac pacemakers...).
- The heating plate can reach temperatures of 280°C and pay attention to the residual heat after switching off.
- The main power supply cable should not touch the heating plate.
- Wear your personal protective equipment in accordance with the hazard category of the media to be processed.
Otherwise there is a risk from:
 - Splashing and evaporation of liquids
 - Ejection of parts
 - Release of toxic or combustible gases
- Set up the device in a spacious area on an even, stable, clean, nonslip, dry and fireproof surface.
- Don't use damaged components.
- Gradually increase the speed and reduce the speed if
 - the medium splashes out of the container because the speed is too high
 - the machine is not running smoothly
 - the container moves on the heating plate
- **Caution!** Only process and heat up any media that has a flash point higher than the adjusted safe temperature limit that has been set.
- The safe temperature limit must always be set to at least 50°C lower than the fire point of the media used.

- Beware of hazards due to:
 - flammable materials
 - combustible media with a low boiling temperature
 - glass breakage
 - incorrect container use
 - overfilling of media
 - unsafe condition of container
- The machine may heat up when in use. Don't use the machine in explosive atmospheres with hazardous substances.
- Process pathogenic materials only in closed containers under a suitable extractor hood.
- Only process media that will not react dangerously to the extra energy produced in other ways, e.g. through light irradiation.
- The external temperature sensor PT1000 must always be inserted in the media when connected and ensure it's inserted in the media to a depth of at least 20mm.
- Accessories must be securely attached to the machine and can't come off by themselves.
- Always disconnect the plug before fitting accessories.
- The machine can only be disconnected from the mains supply by pulling out the mains plug or the connector plug.
- When using PTFE-coated magnetic bars, the following has to be noted, Chemical reactions of PTFE occur in contact with molten or solute alkali metals and alkaline earth metals, as well as with fine powders of metals in groups 2 and 3 of the periodic system at temperatures above 300°C-400°C. Only elementary fluorine, chlorotrifluoride and alkali metals attack it; halogenated hydrocarbons have a reversible swelling effect.
- The voltage stated on the type plate must correspond to the mains voltage.
- Don't cover the machine, even partially e.g. with metallic plates or film, which will result in overheating.
- Ensure the heating plate is kept clean.
- Protect the machine and accessories from bumps and impacts.

- The minimum distance between the machines; the minimum distance between the machine and the wall is mini. 100mm.

Inspection

- Unpack the device carefully and check for any damages which may have arisen during transit. Please contact the manufacturer/supplier for technical support.



Note:

If there is any apparent damage to the device, please do not connect the power line.

- Contents of package

Items	Qty
Main unit	1
Power cable	1
Screwdriver	1
Magnetic stirring bar	1
External temperature sensor PT1000 (optional accessory)	1
User Manual	1

Control

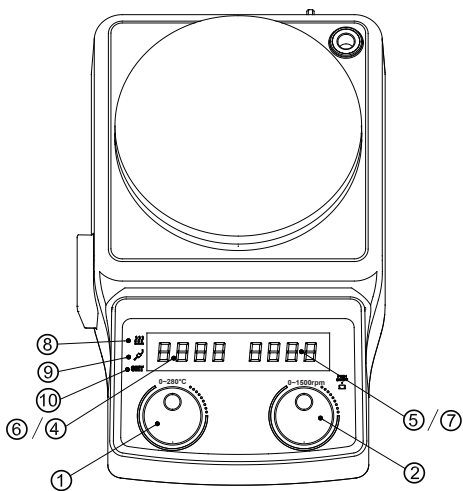
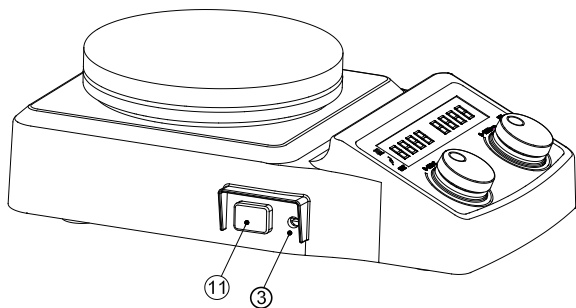

① Knob for temperature setting	Set the temperature by rotating the knob Start/stop heating by pressing the knob
② Knob for speed setting	Set the speed by rotating the knob Start/stop stirring by pressing the knob
③ Knob for safety temperature setting	Set the safety temperature by rotating the knob. When the heating temperature is higher than the safety temperature, the machine stops heating.
④ Temperature display	When heating, it displays the target temperature and the actual temperature alternately. It displays "OFF" when heating stops.
⑤ Speed display	When stirring, it displays the target speed and the actual speed alternately. It displays "OFF" when the stirring stops.
⑥⑦ Safety temperature display	When setting the safety temperature, the first 4 digits display "SAFE" and the last 4 digits display the temperature value.
⑧ Heating indicator	It's lit when heating.
⑨ External temperature sensor indicator	When the external temperature sensor is connected, the indicator is lit and the LED displays the temperature of the external temperature sensor. When it's disconnected, the temperature of the internal temperature sensor is displayed.
⑩ Setting indicator	The light will flash when setting the temperature or speed.
⑪ Power switch	Switch on/off

Trial run

- Make sure the required voltage corresponds to the mains voltage.
- Ensure the socket must be properly grounded.
- Switch on and start initializing.
- Add sample into the container with an appropriate stirring bar.
- Place the container on the heating plate.
- Set the target speed and start stirring.
- Observe the stirring bar and the LED display.
- Set the temperature and start heating.
- Observe the actual temperature on the LED display.
- Connect the external temperature sensor.

If the above operations are normal, the device is good to run. If these operations are abnormal, the device may probably be damaged during transit, please contact manufacturer/supplier for technical support.



Warning!

DO NOT move the container when the device is working.

Heating

With the digital temperature control, the machine has two separate safe circuits. The hotplate is kept at a constant temperature by a digital control circuit. The hotplate temperature can also be monitored by another adjustable safe circuit. The two temperature sensors (PT1000) internal for temperature control are built into the hotplate.

The single external PT1000 can monitor the temperature of sample.

- Set temperature by the temperature setting knob.
- When heating, the LED will display alternately the target temperature and the real temperature.
- Heating is switched on/off by pressing the temperature setting.

- The set temperature of last operation will be displayed when the machine is switched on. Normally, the set temperature and the actual temperature may probably have some differences:
 - Hotplate center and outer edge
 - The sample inside the container and the container.

To ensure the accuracy of the temperature inside the container, please use the external temperature sensor PT1000.

external PT1000 can monitor the temperature of sample.

Working with the external temperature sensor

The external temperature sensor PT1000 is the optional accessory. When the sensor is connected, the sensor indicator will light and the machine is in the PT1000 operation mode. The setting temperature of the external sensor and the actual temperature are displayed. The safety circuit controls the hotplate temperature.

Comparing with the temperature control of the hotplate, the external temperature sensor can control the sample's temperature more precisely. The external temperature sensor must be inserted in the sample. For any faults, heating will be automatically stopped. In this case, please proceed as follows:

- Turn power off
- Ensure the external temperature sensor is inserted into the sample
- Turn on and set the temperature to start heating
- If the instrument still can't work properly, please contact manufacturer / supplier for technical support.

Residual heat warning (HOT)

To prevent the risk of burns from the hotplate, this instrument has residual heat warning function. When heating is stopped, and the heating plate temperature is still above 50°C, "Hot" will

flash to warn that there's potential risk of burns. When the hotplate temperature drops to below 50°C, the instrument will be automatically powered off. To turn off the instrument immediately, pull out the plug. In case of main power failure or disconnection, the residual heat warning will not work.

Stirring

Stirring is switched on / off by pressing the speed setting knob. The speed is set by rotating the knob in the range of 100-1500rpm. When powered on, it displays the set speed of last operation.

Faults

- The device can't work when powered on
 - Check if the power line is connected properly
 - Check if the fuse is broken or loose
- Fault in power on self test
 - Power off the device and then restart
- Actual speed can't reach the set value
 - Media in high viscosity may probably cause abnormal speed reduction of the motor
- The device can't be powered off when switched off
 - Check if the residual heat warning function is still on and the hotplate temperature is above 50°C (LED still works and "Hot" flashes)

Error codes

Error code	Error description	Solutions
Er1	Short circuit in the external temperature sensor PT1000	Replace PT1000 and re-start the device
Er2	Open circuit in the internal temperature sensor PT1000	Re-start the device
Er3	Short circuit in the internal temperature sensor PT1000	Re-start the device
Er4	Excessive temperature of the device	Power off, and then re-startthe device after cooling down
Er5	Motor failure	Reduce the sample

If the instrument still can't work properly, please contact manufacturer/supplier for technical support.

Maintenance

Proper maintenance can make the device work well and extend its life.

- Do not allow moisture to get into the device when cleaning
- Disconnect the mains plug when cleaning
- Wear protective gloves when cleaning
- Only use the recommended cleansing agents

Dyes	Isopropyl alcohol
Construction materials	Water containing surfactant / Isopropyl alcohol
Cosmetics	Water containing surfactant / Isopropyl alcohol
Foodstuffs	Water containing surfactant
Fuels	Water containing surfactant

Standards and regulations

Construction in accordance with the following safety standards:

EN 61010-1

UL 3101-1

CAN/CSA C22.2(1010-1)

EN 61010-2-10

Construction in accordance with the following EMC standards:

EN 61326-1

Associated EU guidelines:

EMC-guidelines: 89/336/EWG

Instrument guidelines: 73/023/EWG

Specifications

Voltage [VAC]	200-240/100-120
Frequency [Hz]	50/60
Power [W]	630
Stirring point position quantity	1
Max. stirring quantity (H ₂ O) [L]	5
Max. magnetic bar [L x Φ , mm]	55 x 10
Motor Type	DC motor
Max. power input of motor [W]	3
Max. power output of motor [W]	2.5
Speed range [rpm]	100-1500
Speed display	LED
Working-plate material	Stainless steel with ceramic coated
Dimension of working plate (mm)	Φ 135
Heating power [W]	600
Temperature range [°C]	RT-280
Temperature display [°C]	LED
Temperature display accuracy [°C]	± 0.1
Safety temperature [°C]	50-320
External temperature sensor (optional accessory)	PT1000
Control accuracy with the external temperature sensor [°C]	± 1
Residual heat warning	50°C
Dimensions [W x D x H, mm]	268x160x86
Weight[kg]	1.8
Permissible ambient temperature [°C]	5-40
Permissible relative humidity	80%
Protection class acc. to DIN EN6 0529	IP42

Warranty

The instrument is warranted to be free from defects in materials and workmanship under normal use and service for a period of 24 months from the date of invoice. The warranty is extended only to the original purchaser. It doesn't cover any worn out parts, nor apply to any damage by improper use, insufficient care or maintenance not carried out in accordance with the instructions in this operating manual.

For claims under the warranty please contact your local supplier. You may also send the instrument directly to manufacturer, enclosing the invoice copy and giving reasons for the claim.

目录

符合性声明	15
安全说明	15
正确使用	17
开箱	16
控制	16
试运行	19
加热	20
使用外部温度传感器	20
余热警告 (热)	20
搅拌	21
故障排除	21
错误代码	21
清洁与维护	22
技术参数	22
保修	23

符合性声明

我公司自行负责声明本产品符合 2014/35/EU, 2006/42/EC, 2014/30/EU 和 2011/65/EU 指令, 并符合以下标准或标准性文档: EN 61010-1, EN 61010-2-010, EN 61010-2-051, EN 61326-1, EN 60529 和 EN ISO 12100.

安全说明



/// 一般信息

- 操作仪器前请认真阅读使用说明并遵守安全操作规范。
- 请将本使用说明放置于使用者方便查阅的地方。
- 确保只有受过相关训练的人员才能操作本仪器。
- 请遵守安全规范、人身安全和事故防止等相关规范。
- 电源插座必须接地保护。
- **注意 – 磁场!**
使用时需考虑磁场对周边环境的影响, 如数据存储器, 心脏起搏器。
- **小心高温!**
触摸仪器外壳和盘面时小心烫伤。
仪器工作时盘面可能处于高温状态。仪器关闭后, 也请注意余热。
只有当盘面处于冷却状态时才可搬运仪器!

/// 仪器设计

- 禁止在爆炸性环境中使用本仪器; 本仪器不具有防爆功能。
- 处理能够形成爆炸性混合物的物质, 必须采取符合相关标准的安全措施。
例如, 在通风处下工作。
- 为避免人身伤害和财产损失, 请在处理危险物品时遵守相关的安全和事故预防措施。
- 请将仪器放置于水平、平稳、清洁、防滑、干燥和防火的台面。
- 仪器支脚必须清洁无损。
- 请注意避免仪器电源线/温度传感器线缆接触盘面。
- 每次使用前请检查仪器和配件并确保无损, 请勿使用损毁的仪器和配件。

/// 允许介质/污染物/不良反应

- 本仪器仅适用于对处理过程中产生的能量不发生危险反应的介质; 同时被处理的物质也不能与其它方式产生的能量反应, 如光照。

- 注意以下可能产生的危险:
 - 易燃物质。
 - 低沸点可燃物质。
 - 易碎玻璃容器。
 - 容器大小不合适。
 - 溶液过量。
 - 容器处于不安全状态。
- 处理病原体介质时, 请使用密闭容器并在合适的通风橱中进行。
- 为保证无人监控下的安全操作, 请仅处理闪点高于安全温度值的介质。仪器安全温度设定值应该至少低于介质闪点25 °C。(EN 61010-2-010)
- 即使没有开启加热功能, 由于磁力搅拌子的高速转动, 也有可能导致仪器盘面升温。
- 请考虑到任何可能的污染和有害的化学反应。
- 仪器转动部件的磨损产生的碎片有可能接触到所处理的介质。
- 使用 PTFE 覆膜的磁力搅拌子请注意可能出现下列问题: 温度高于 300 °C – 400 °C时, 碱或碱土金属熔融态或者溶液以及元素周期表的第二族及第三族的粉末会跟PTFE 发生化学反应。常温下, 只有金属单质氟, 三氟化物和碱金属会侵蚀 PTFE, 卤烷烃会使其膨胀。

/// 实验步骤

- 根据处理介质的种类, 在操作仪器时请佩戴合适的防护装置, 注意下列可能出现的危险:
 - 液体溅出。
 - 部件飞出。
 - 释放出有毒或者可燃气体。
- 出现下列状况时, 请降低转速:
 - 由于转速过高导致所处理的介质溅出容器。
 - 仪器运转不平稳。
 - 容器在加热盘上发生移动。
 - 仪器出现故障。

/// 选配件

- 只有使用机器原装选配件才可确保安全。
- 使用温度计时, 请确保温度探头浸入介质深度至少20mm。
- 安装配件前请断开电源。
- 使用配件时, 必须安装牢固, 且在安装完毕后整个系统的重心不能超出系统之外。
- 使用任何配件时都须遵守选配件的操作说明。

/// 电源/关机

- 输入电压必须与仪器铭牌上标示的电压一致。
- 电源插座必须易于使用和操作。
- 只有拔下仪器电源插头才能完全切断电源。

/// 仪器保护

- 只有受过专业培训的维修人员才能打开仪器。
- 使用时，请勿使用外物盖住仪器，否则将会导致仪器过热。
- 确保仪器和配件免受挤压和碰撞。
- 请确保仪器盘面清洁。
- 确保仪器放置间距合理：
 - 仪器之间至少 100 mm。
 - 仪器距离四周墙壁至少 100 mm。
 - 仪器距离上方至少 800 mm。

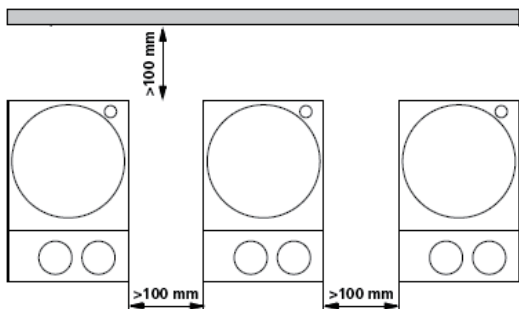

正确使用

/// 应用

- 仪器适用于搅拌 / 加热物质。

/// 使用区域

- 在研究、教学、商业或工业领域中的实验室式的室内环境。
- 出现下列情况时我们将无法确保使用者的安全：
 - 如果使用了非厂家提供或推荐的选配件。
 - 如果仪器操作有误或者违反了厂家的操作规范。
 - 如果仪器或者电路板被第三方非法修改。

开箱

/// 开箱检查

- 请小心拆除包装并检查仪器
- 如果发现任何破损，请填写破损报告并立即通知货运公司

⚠ 注意：

如果设备有明显损坏，请不要连接电源线。

- 包装清单

项目	数量
主机	1
电源线	1
螺丝刀	1
磁力搅拌棒	1
外部温度传感器PT1000（选配）	1
用户手册	1

控制

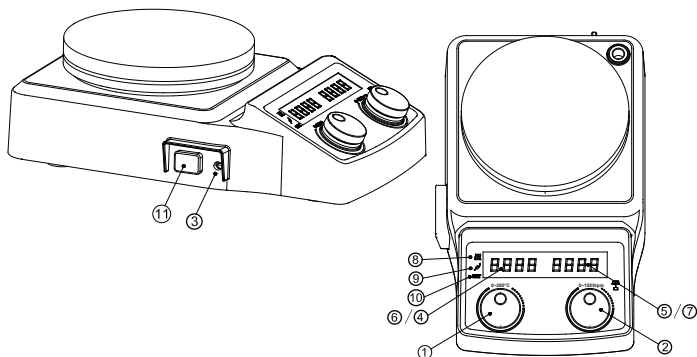

① 温度设定旋钮	转动旋钮来设定温度 按下旋钮启动/停止加热
② 速度设定旋钮	通过旋转旋钮来设定速度 按下旋钮开始/停止搅拌
③ 安全温度设置旋钮	旋转旋钮设置安全温度。当加热温度高于安全温度，机器停止加热。
④ 温度显示	加热时，显示目标温度和实际温度交替变化。 当停止加热时显示“OFF”。
⑤ 速度显示	搅拌时，显示目标速度和实际速度交替变化。 搅拌停止时显示“OFF”。
⑥⑦ 安全温度显示	设置安全温度时，前4位数字显示“SAFE”， 最后4位数字显示温度值。
⑧ 加热指示灯	加热时指示灯亮起
⑨ 外部温度传感器指示灯	当连接外部温度传感器时指示灯亮起，LED 显示外部温度传感器。当它断开时显示内部 温度传感器的温度。
⑩ 设置指示器	设置温度或速度时，灯将闪烁。
⑪ 电源开关	控制通电/断电

试运行

- 确保机器所需电压符合电源电压。
- 确保插座已经正确接地。
- 打开并开始初始化。
- 在容器中加入样品并使用适当的搅拌棒。
- 将容器放在加热盘上。
- 设定目标速度并开始搅拌。
- 观察搅拌棒和LED显示屏。
- 设置温度并开始加热。
- 观察LED显示屏上的实际温度。
- 连接外部温度传感器。

如果上述操作正常，则设备可以良好运行。如果这些操作异常，设备可能在运输途中损坏，请联系技术支持的制造商/供应商。

加热

通过数字温度控制，机器有两个分离安全电路。加热盘保持恒定温度由数字控制电路控制。加热盘温度也可以通过另一个可调的安全电路，两个温度传感器（PT1000）内部温度控制内置在加热盘中。单个外部PT1000可监测样本的温度。

- 通过温度设置旋钮设置温度。
- 加热时，LED将交替显示目标温度和真实温度。
- 按下温度开关加热设置。
- 当机器开机时显示上次操作的设定温度。

一般来说设定温度和实际温度可能有一些不同：

- 加热盘中心和外缘
- 容器和容器内的样品。

为确保容器内部温度的准确性，请使用外部温度传感器PT1000。

使用外部温度传感器

外部温度传感器PT1000是标准配件。当传感器连接时，指示灯亮，并且机器处于PT1000操作模式。外部的设定温度显示传感器和实际温度。这个安全电路控制加热盘温度。与加热盘的温度控制相比，外部温度传感器可以更精确控制样品的温度。

外部温度传感器必须插入样品中。出现任何错误，加热将自动停止。在这种情况下，请按以下步骤进行：

- 关闭电源
- 确保插入外部温度传感器进入样品
- 打开并设置温度以开始加热
- 如果仪器仍然不能正常工作，请联系制造商/供应商获取技术支持。

余热警告（热）

为了防止烫伤的危险，本仪表具有余热报警功能。当停止加热，加热盘温度为仍高于50°C时，“Hot”指示灯将闪烁以警告潜在烧伤风险。当加热盘温度降至50°C以下，仪器将自动关机。要立即关闭仪器，请拉出拔出插头。主电源故障或断开连接，余热警告将不起作用。

搅拌

通过按下速度设置旋钮来开始/停止搅拌。通过旋转转速设置旋钮来设置转速，转速调节范围：50-1500转/分。通电时，显示设置上次设定的速度。

故障排除

- 开机时设备无法工作
 - 检查电源线是否连接正确
 - 检查保险丝是否断开或松动
- 开机自检故障
 - 关闭设备电源，然后重新启动
- 实际速度达不到设定值
 - 高粘度样品可能导致异常电动机减速
- 关机时无法关机
 - 检查余热警告功能是否仍处于开启状态并且加热板温度高于50°C (LED仍然亮起和“Hot”闪烁)

错误代码

错误代码	错误描述	解决方案
Er1	外部温度传感器PT1000短路	更换PT1000和重新启动设备
Er2	内部温度传感器PT1000断路	联系制造商维修
Er3	内部温度传感器PT1000短路	联系制造商维修
Er4	设备温度过高	关机，设备冷却后重新启动
Er5	电机故障	联系制造商维修

如果仪器仍然不能正常工作，请联系技术支持的制造商/供应商。

清洁与维护

本仪器无需特殊保护。

清洁

- 清洁仪器须断开电源!
- 清洁仪器时请仅用本公司认可的清洁液: 含活性剂的水溶液和异丙醇
- 清洁仪器时请佩戴防护手套。
- 清洁时, 请勿将电子设备放置于清洁剂中。
- 清洁时, 请勿让潮气进入仪器。
- 当采用其他非本公司推荐的方法清洁时, 请先向我们确认清洁方法不会损坏仪器。

维修

在送检您的仪器之前, 请先清洁并确保仪器内无任何对人健康有害的物料残留。

如需维修服务, 请使用原包装箱妥善包装后将仪器寄回。如原包装不存在时请采用合适的包装。

技术参数

电压[VAC]	200-240/100-120
频率[Hz]	50/60
功率[W]	630
搅拌点位数量	1
最大搅拌量 (H ₂ O) [L]	5
最大磁棒[L xΦ, mm]	55 x 10
电机类型	直流有刷电机
电动机最大功率输入[W]	5
电动机最大输出功率[W]	3
转速范围[rpm]	100-1500
速度显示	LED
工作盘材料	不锈钢+陶瓷涂层

工作盘尺寸[mm]	Φ137
加热功率	600
温度范围[°C]	RT-280
温度显示[°C]	LED
温度显示精度[°C]	±0.1
安全温度[°C]	50-320
外部温度传感器	PT1000
外部温度传感器控制精度[°C]	±1
余热报警	50°C
尺寸[长x宽x高, mm]	268x160x85
重量[kg]	1.8
允许环境温度[°C]	5-40
允许相对湿度	80%
DIN EN60529防护等级	IP42

保修

本设备保修 2 年。保修期内如果有任何质量问题请联络您的供货商，或者联系我公司售后服务部门寻求支持。保修不包括零件的自然磨损，也不适用于过失、不当操作或者未按操作说明书使用和维护引起的损坏。